

# Brake

FRATO 120

ref: 321.420.00

## Specifications

Nominal torque	12	N.m	<i>ft.lbf</i>	<b>9</b>
Minimal torque	0.14	N.m	<i>ft.lbf</i>	<b>0.1</b>
Coil resistance - 20°C			<i>W</i>	<b>23</b>
Rated current DC			<i>A</i>	<b>0.55</b>
Rotor inertia	0.25.10 <sup>-3</sup>	kg.m <sup>2</sup>	<i>lb.ft<sup>2</sup></i>	<b>5.8 10<sup>-3</sup></b>
Weight	3.4	kg	<i>lb</i>	<b>7.5</b>
Heat dissipation continuous sustained with water flow (120 l/h)			<i>W *</i>	<b>400</b>

\* Heat dissipation is the mechanical power ( $P = cw$ ) maximum allowable.

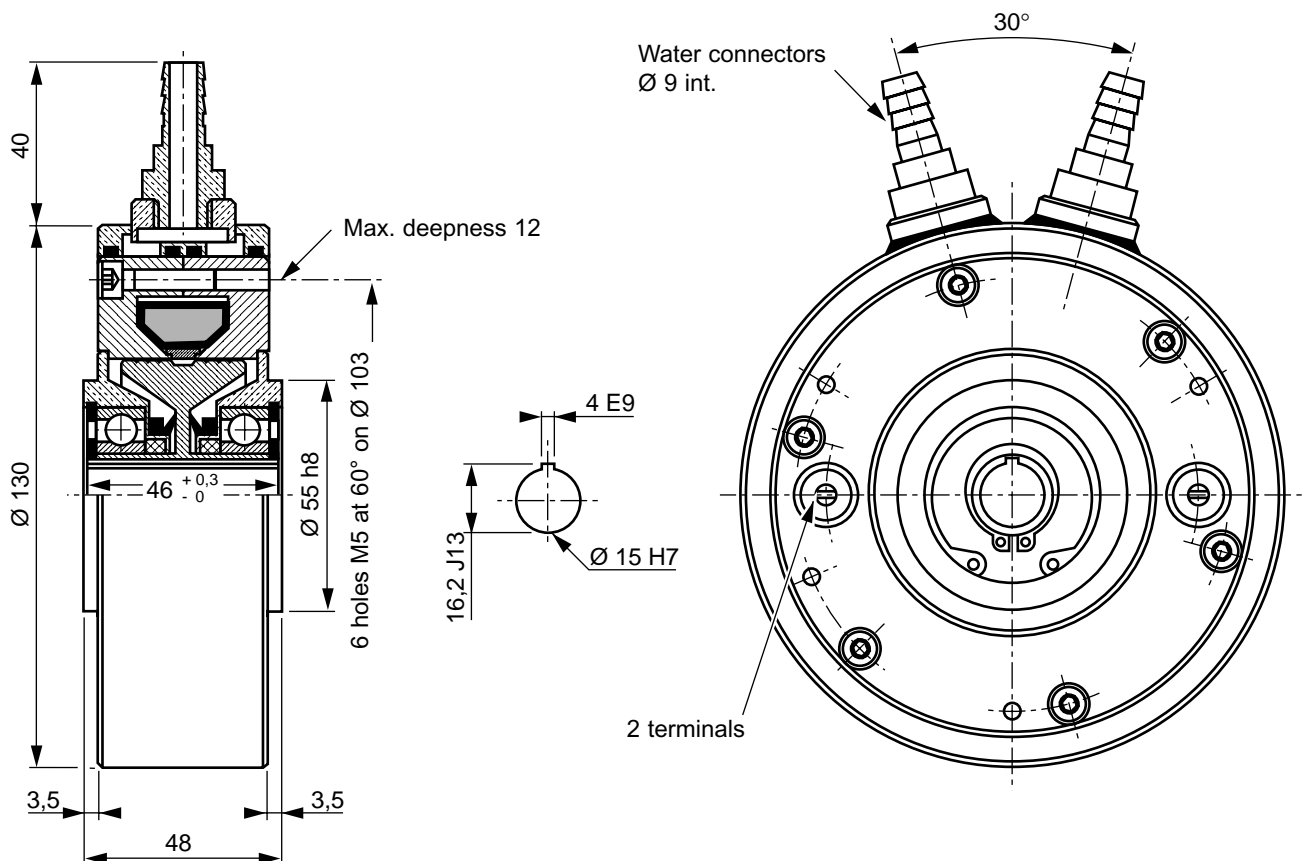
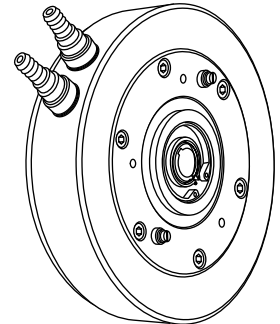

## Utilization

- Mounting must be made without any stress.  
Lubricated for life (other internal lubrication not allowed).  
The shaft should be lubricated upon assembly, to prevent seizing.
- Low DC current power supply for coil.  
(See MEROBEL Electronic data sheets )
- The standard device is designed for horizontal shaft orientation,  
and a minimal speed of 60 RPM. Maximum speed is 3000 RPM  
(without exceeding the max. heat dissipation capability).
- For Engineering application, please contact our technical support.
- In normal use, the outside temperature of the device can increase up to 100°C,  
without damage.

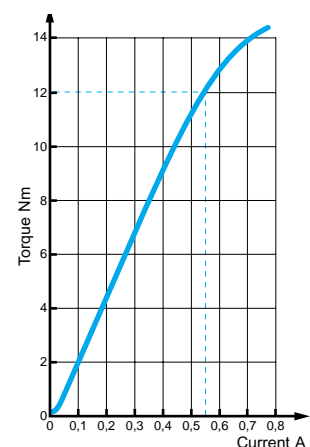

## Safety

- If the device is to be used in dusty, humid or corrosive environment, special protection needs to be considered.
- To protect the device from overheating, a thermal sensor can be added.
- During a long stop, water flow must be interrupted to avoid condensation on the device.

## Maintenance

- Two procedures are available:
  - Full inhouse maintenance servicing:
 

<b>MEROBEL Inc.</b> after sales	Ph 732 493 3232
1705 Valley Road	Fax 732 493 2949
Wanamassa, NJ 07712	
  - Spare parts or repair kits (depending on maintenance level) :
 

- Kit (powder, ball bearings, seals, felts)	ref: 812.010.00
- Coil	ref: 321.300.07
- Rotor	ref: 315.300.03
- In any case, our After Sales service is at your disposal.

## Recommended mounting principles

