

Brake

FRAT 10001
ref: 331.210.00

Specifications

Nominal torque	1000	N.m	<i>ft.lbf</i>	752
Minimal torque	10	N.m	<i>ft.lbf</i>	7.52
Coil resistance - 20°C			<i>W</i>	20
Rated current DC			<i>A</i>	1.70
Rotor inertia	0.81	kg.m ²	<i>lb.ft²</i>	18.8
Weight	160	kg	<i>lb</i>	353
Heat dissipation	(W)*			
continuous sustained without ventilation				4000
continuous sustained with MEROBEL ventilation				9300

* Heat dissipation is the mechanical power ($P = cw$) maximum allowable.

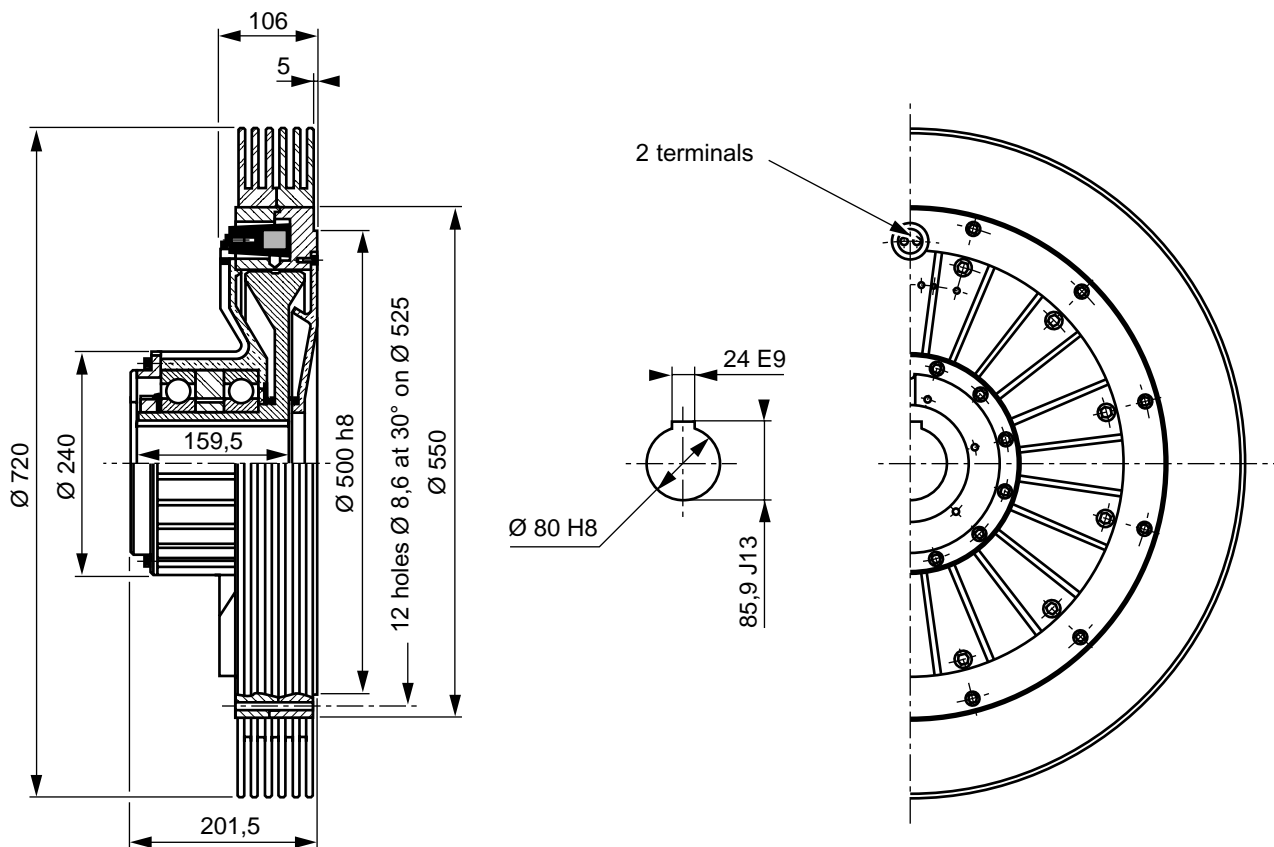
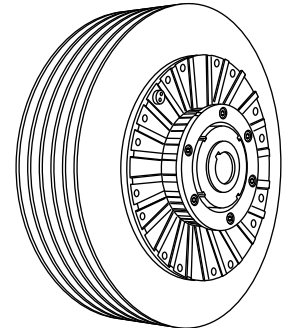

Utilization

- Mounting must be made without any stress.
Lubricated for life (other internal lubrication not allowed).
The shaft should be lubricated upon assembly, to prevent seizing.
- Low DC current power supply for coil.
(See MEROBEL Electronic data sheets)
- The standard device is designed for horizontal shaft orientation, and a minimal speed of 60 RPM. Maximum speed is 1000 RPM (without exceeding the max. heat dissipation capability).
- For Engineering application, please contact our technical support.
- In normal use, the outside temperature of the device can increase up to 100°C, without damage.

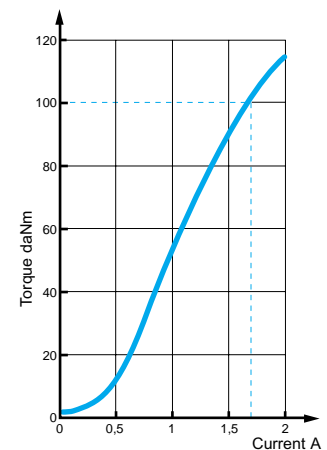

Safety

- If the device is to be used in dusty, humid or corrosive environment, special protection needs to be considered.
- To protect the device from overheating, a thermal sensor can be added.

Maintenance

- Two procedures are available:
 - Full inhouse maintenance servicing:

MEROBEL Inc. after sales	Ph : 732 493 3232
1705 Valley Road	Fax: 732 493 2949
Wanamassa, NJ 07712	
 - Spare parts or repair kits (depending on maintenance level):

- Kit (powder, ball bearings, seals, felts)	ref: 314.500.72
- Coil	ref: 331.200.14
- Rotor	ref: 331.200.06
- In any case, our After Sales service is at your disposal.

Recommended mounting principles

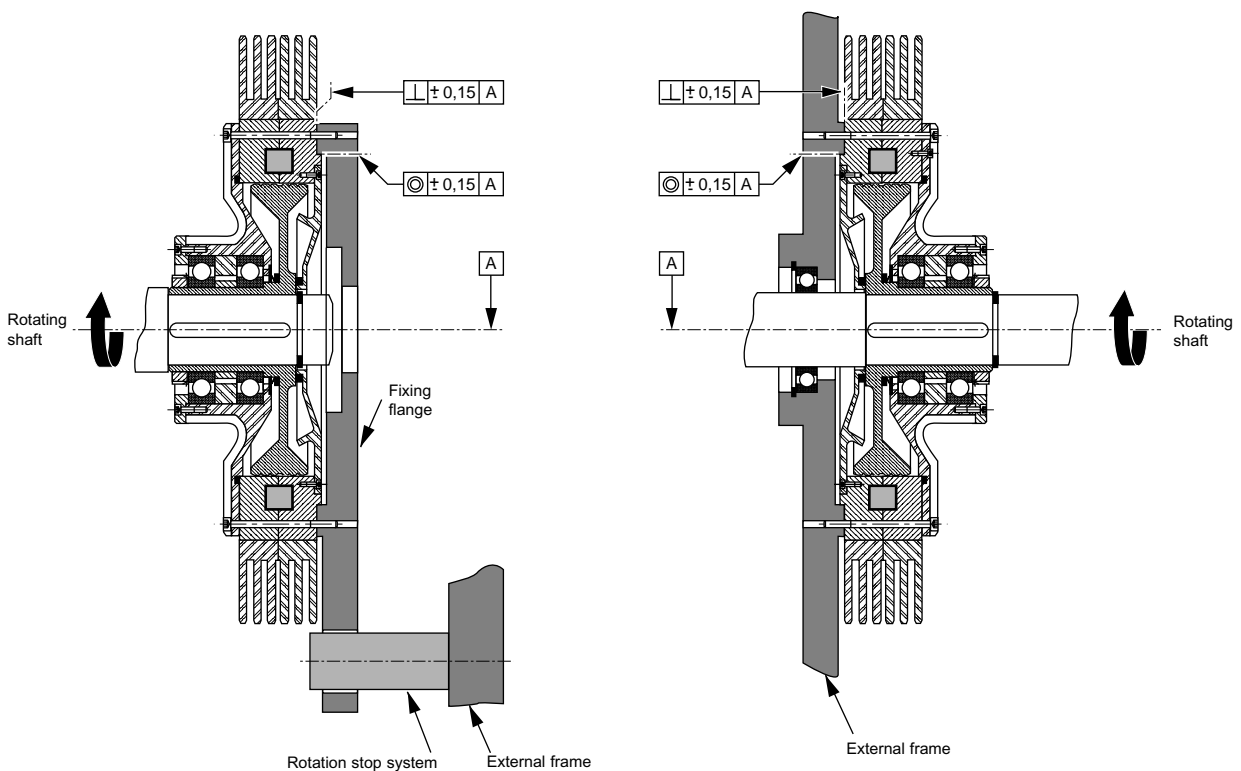

The device is mounted in parallel shaft. It is immobilized to the external frame by a mechanical spare which is adapted to the force.

The device is directly mounted on the external frame and is supported by the reference surface and the centering. It is necessary to respect the mounting principles in order to avoid any mechanical strain on ball bearings.